

GM - Miniaturmagnet

Datenblätter

GM - Miniature solenoid

Datasheets

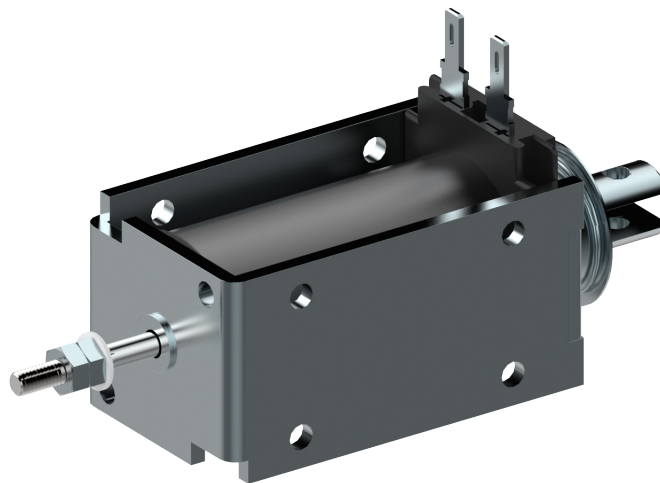

Übersicht / Overview

Typ Type	Dimensionen Dimensions [mm]	Hub Stroke [mm]	F_{min} F_{min} [N]
GM-20.05	23 x 20 x 40	5	1.9
GM-26.08	30 x 26 x 50	8	3.5
GM-35.10	40 x 35 x 60	10	7

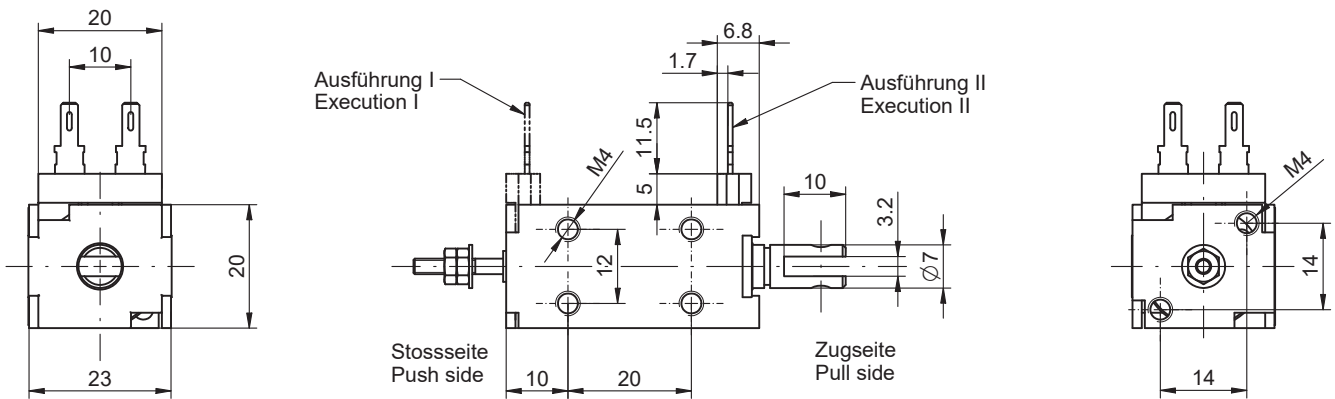

Magnet bestromt gezeichnet
Solenoid illustrated in energised position

Max. Einschraubtiefe der Befestigungsschrauben ist 2 mm

Max. depth of thread for fixing screw = 2 mm

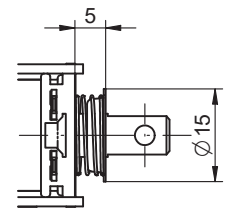
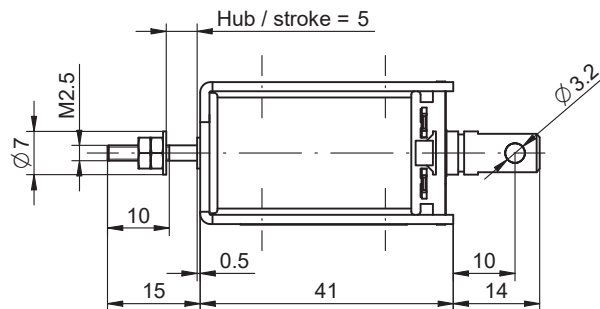

Mit Federrückstellung
with return spring

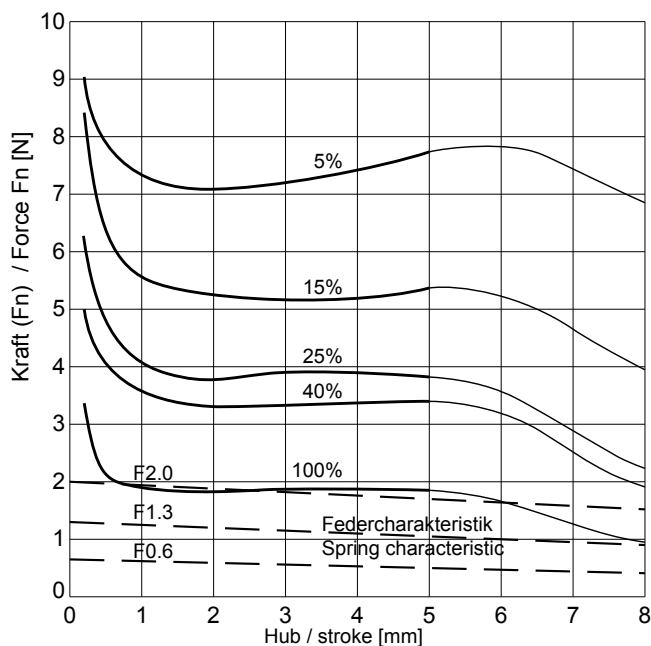

ED [%]	100	40	25	15	5	Duty cycle [%]
Die Spieldauer für die Berechnung der Einschaltdauer beträgt 30 sec.						The max. duty cycle time to determine the duty cycle is 30 sec.
Hubarbeit [Ncm]	1.0	1.8	2.0	2.6	3.8	Work done [Ncm]
El. Leistung [W] (P20)	8.2	19	27	47	145	Power [W] (P20)
Anzugszeit [ms]	45	44	42	41	40	Operating time [ms]
Abfallzeit [ms]	30	27	24	21	18	
(+20°C, betriebswarm, bei Belastung mit 70% der entsprechenden Magnetkraft)						(+20°C, operating temperature, with a load equal to 70% of the solenoid force)

■ = Nicht Standard / not standard

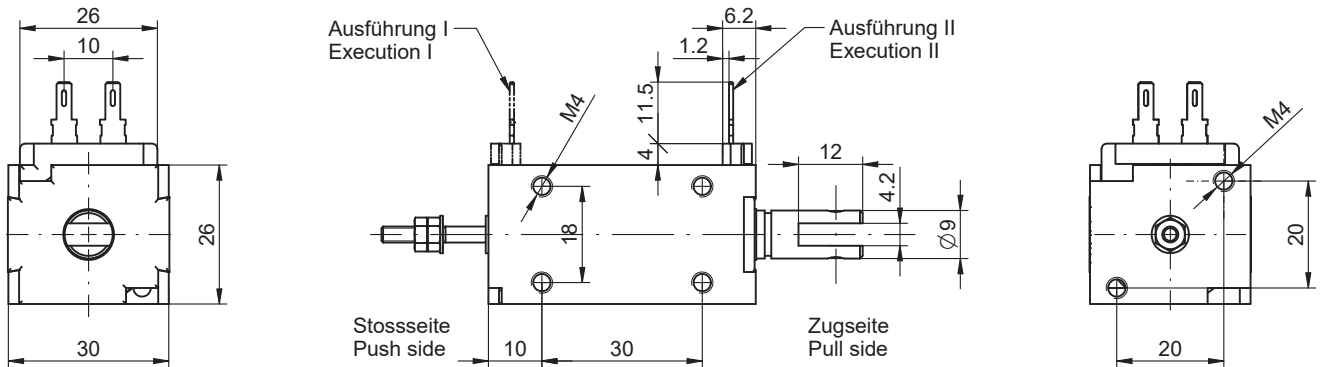
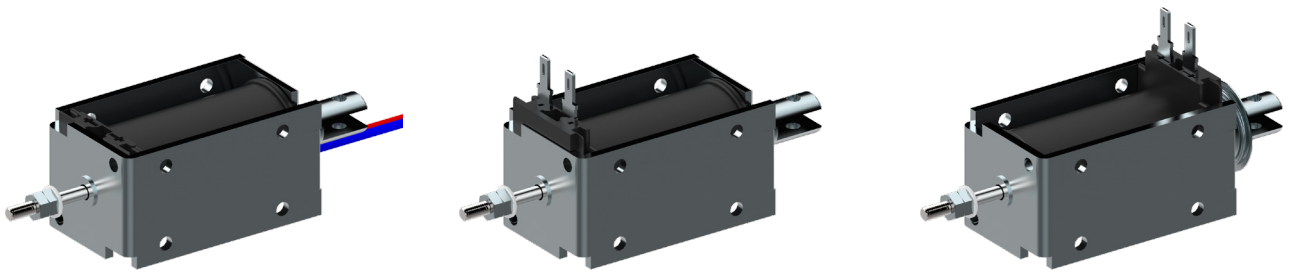

Magnet bestromt gezeichnet
Solenoid illustrated in energised position

Max. Einschraubtiefe der Befestigungsschrauben ist 3 mm

Max. depth of thread for fixing screw = 3 mm

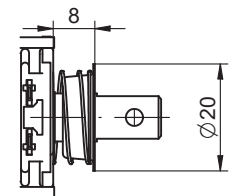
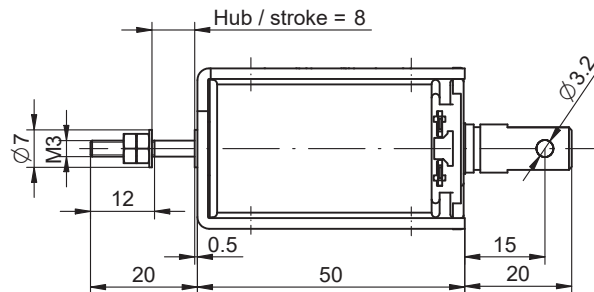

Mit Federrückstellung
with return spring

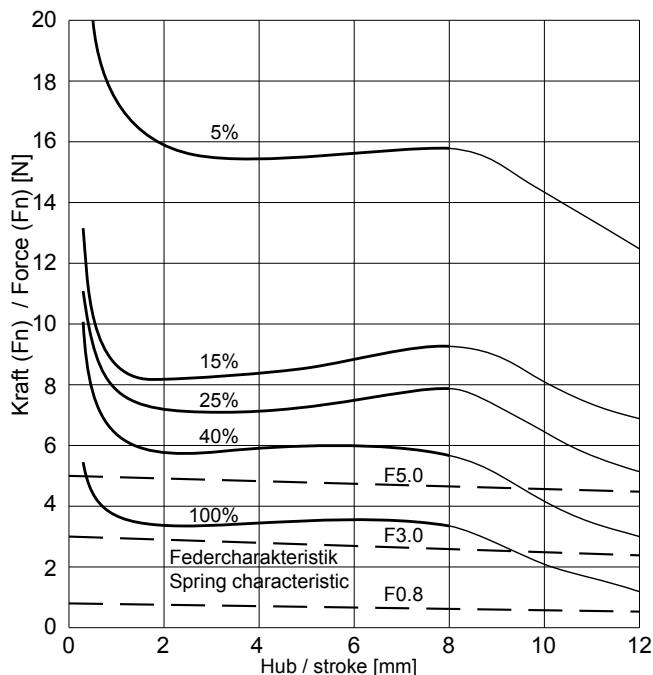

ED [%]	100	40	25	15	5	Duty cycle [%]
Die Spieldauer für die Berechnung der Einschaltdauer beträgt 30 sec.						The max. duty cycle time to determine the duty cycle is 30 sec
Hubarbeit [Ncm]	2.8	4.8	5.6	7.2	12.4	Work done [Ncm]
El. Leistung [W] (P20)	12	28	44	70	200	Power [W] (P20)
Anzugszeit [ms] Abfallzeit [ms]	65 45	62 40	60 35	57 30	55 25	Operating time [ms] Release time [ms]
(+20°C, betriebswarm, bei Belastung mit 70% der entsprechenden Magnetkraft)						(+20°C, operating temperature, with a load equal to 70% of the solenoid force)

■ = Nicht Standard / not standard

Spezifikationen

Specifications

Funktion	ziehend / stossend	pull / push	Operation
Vorzugs-Nennspannung	24VDC (max. 50VDC)		Preferred rated voltage
Isolierstoffklasse	B (130°C) DIN VDE 0580		Class of insulation
Prüfspannung Überspannungskategorie	EN 60664-1 III		Test voltage Surge category
Schutzart	IP00 (IEC 60529)		Degree of protection
El. Anschlussart	Steckzungen 2.8 x 0.8 DIN 46342-1 Litzen (300mm), AWG20	2.8 x 0.8 Tabs DIN 46342-1 Lead wires (300mm), AWG20	Electrical termination
Oberflächenbehandlung	Gehäuse verzinkt & blau passiviert, Anker hartverchromt	Solenoid housing zinc plated & trivalent chrome passivated, plunger hard chrome-plated	Surface treatment
bewegte Masse	0.027kg		Moving mass
Total Magnetgewicht	0.180kg		Total weight of solenoid

Bestellbeispiel

Ordering specification

GMs - 26.08 - 100 U - 24 I F 0.8 "D"

<p>Gleichstrom-Miniatur-Magnet</p> <p>s: mit Stossstange ohne Index keine Stossstange</p> <p>Baugrösse</p> <p>Nennhub des Magneten in mm</p> <p>Einschaltdauer (ED) in %</p> <p>U: Universalanschluss W: Litzenanschluss</p> <p>Spannung in Volt</p> <p>I Anschlüsse auf Stossseite II Anschlüsse auf Zugseite</p> <p>Mit Rückstellfeder Ohne Rückstellfeder kein Index</p> <p>Index der Federkennlinie</p> <p>"D": mit Dämpfung (nur mit Feder möglich) ohne Index keine Dämpfung</p>		<p>Type GM: D.C. Miniature solenoid</p> <p>s: with push rod without push rod - no index</p> <p>Size</p> <p>Rated stroke of solenoid in mm</p> <p>Duty cycle in %</p> <p>U: Universal termination W: Lead wire</p> <p>Voltage</p> <p>I Electrical termination on push side II Electrical termination on pull side</p> <p>With return-spring assembly Without spring - no index</p> <p>Index of return-spring</p> <p>"D": with damping (only possible with spring) Without damping - no index</p>
--	--	---

Bemerkungen

Notes

- Magnete hergestellt und geprüft nach DIN VDE 0580
- Magnetkraft betriebswarm gemessen bei 20°C Umgebungstemperatur, waagrecht Bewegungsrichtung mit 90% Nennspannung
- Die Magnethaftkraftwerte gelten nur als Referenzwerte und können infolge Toleranzen um ±10% abweichen
- Sonderausführungen sind lieferbar
- Änderungen vorbehalten - Abbildungen unverbindlich
- RoHS konform, frei von Halogenen (PVC)
- Unsere „Technischen Erläuterungen“ geben Auskunft über den Einsatz von Magneten sowie zu allgemeinen Montage- und Sicherheitshinweisen

- Solenoids manufactured and tested according to DIN VDE 0580
- Forces indicated measured at 20°C ambient and operating temperature with 90% of its rated voltage, in horizontal position
- Force values for reference only and can differ ±10% as a result of natural dispersion
- Special designs are available
- All specifications subject to change without notice
- Compliant with RoHS; free of halogenes (PVC)
- Our „Technical Explanations“ provide information about the use of solenoids as well as to general installation and safety instructions

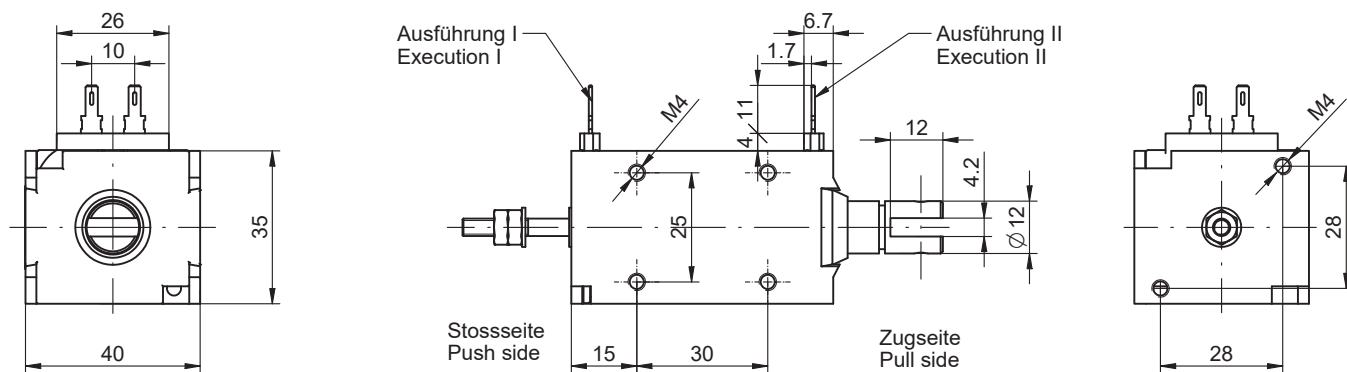
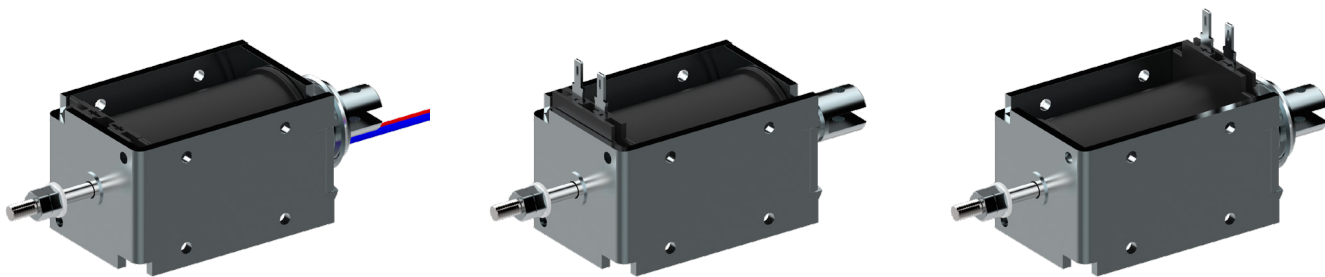

Magnet bestromt gezeichnet
Solenoid illustrated in energised position

Max. Einschraubtiefe der Befestigungsschrauben ist 4 mm

Max. depth of thread for fixing screw = 4 mm

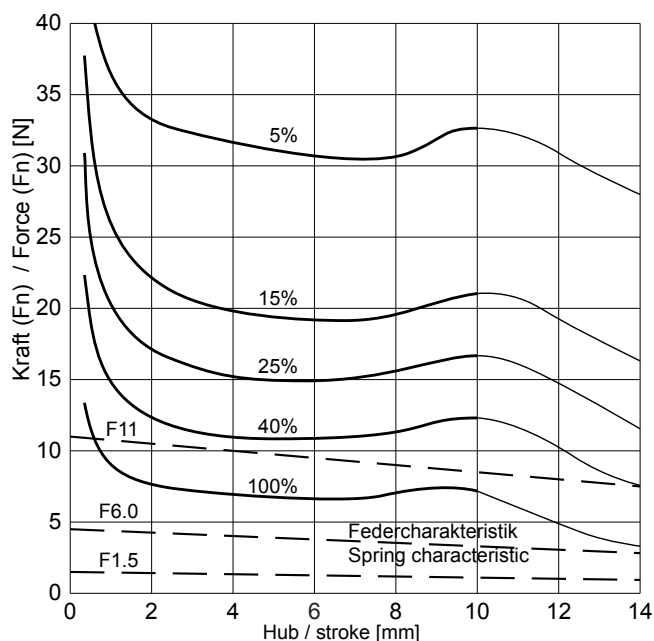
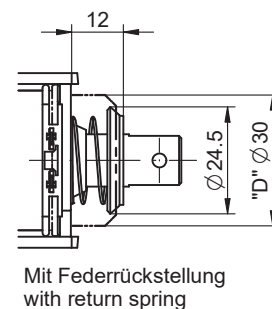
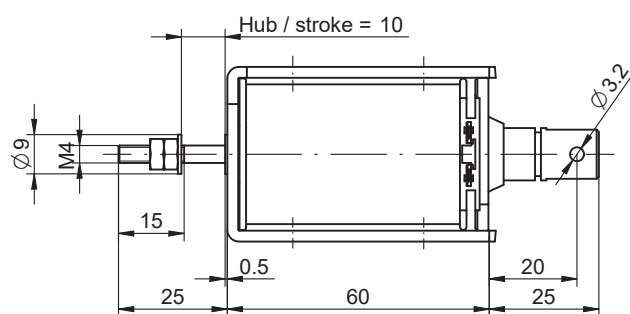

ED [%]	100	40	25	15	5	Duty cycle [%]
Die Spieldauer für die Berechnung der Einschaltdauer beträgt 30 sec.						The max. duty cycle time to determine the duty cycle is 30 sec.
Hubarbeit [Ncm]	7.5	12	17	21	32	Work done [Ncm]
El. Leistung [W] (P20)	17	42	66	111	350	Power [W] (P20)
Anzugszeit [ms] Abfallzeit [ms]	110 80	100 65	85 60	80 55	75 50	Operating time [ms] Release time [ms]
(+20°C, betriebswarm, bei Belastung mit 70% der entsprechenden Magnetkraft)						(+20°C, operating temperature, with a load equal to 70% of the solenoid force)

■ = Nicht Standard / not standard

Spezifikationen

Specifications

Funktion	ziehend / stossend	pull / push	Operation
Vorzugs-Nennspannung	24VDC (max. 50VDC)		Preferred rated voltage
Isolierstoffklasse	B (130°C) DIN VDE 0580		Class of insulation
Prüfspannung Überspannungskategorie	EN 60664-1 III		Test voltage Surge category
Schutzart	IP00 (IEC 60529)		Degree of protection
El. Anschlussart	Steckzungen 2.8 x 0.8 DIN 46342-1 Litzen (300mm), AWG20	2.8 x 0.8 Tabs DIN 46342-1 Lead wires (300mm), AWG20	Electrical termination
Oberflächenbehandlung	Gehäuse verzinkt & blau passiviert, Anker hartverchromt	Solenoid housing zinc plated & trivalent chrome passivated, plunger hard chrome-plated	Surface treatment
bewegte Masse	0.058kg		Moving mass
Total Magnetgewicht	0.420kg		Total weight of solenoid

Bestellbeispiel

Ordering specification

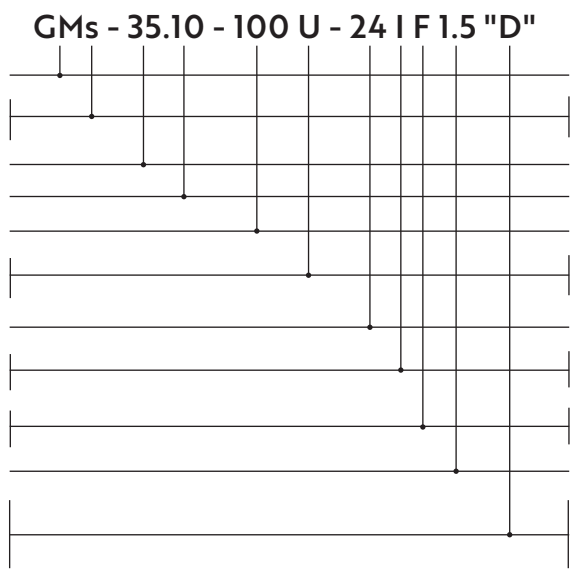
GMs - 35.10 - 100 U - 24 I F 1.5 "D"		
<p>Gleichstrom-Miniatur-Magnet</p> <p>s: mit Stossstange ohne Index keine Stossstange</p> <p>Baugrösse</p> <p>Nennhub des Magneten in mm</p> <p>Einschaltdauer (ED) in %</p> <p>U: Universalanschluss W: Litzenanschluss</p> <p>Spannung in Volt</p> <p>I Anschlüsse auf Stossseite II Anschlüsse auf Zugseite</p> <p>Mit Rückstellfeder Ohne Rückstellfeder kein Index</p> <p>Index der Federkennlinie</p> <p>"D": mit Dämpfung (nur mit Feder möglich) ohne Index keine Dämpfung</p>		<p>Type GM: D.C. Miniature solenoid</p> <p>s: with push rod without push rod - no index</p> <p>Size</p> <p>Rated stroke of solenoid in mm</p> <p>Duty cycle in %</p> <p>U: Universal termination W: Lead wire</p> <p>Voltage</p> <p>I Electrical termination on push side II Electrical termination on pull side</p> <p>With return-spring assembly Without spring - no index</p> <p>Index of return-spring</p> <p>"D": with damping (only possible with spring) Without damping - no index</p>

Bemerkungen

Notes

- Magnete hergestellt und geprüft nach DIN VDE 0580
- Magnetkraft betriebswarm gemessen bei 20°C Umgebungstemperatur, waagrecht Bewegungsrichtung mit 90% Nennspannung
- Die Magnethaftkraftwerte gelten nur als Referenzwerte und können infolge Toleranzen um ±10% abweichen
- Sonderausführungen sind lieferbar
- Änderungen vorbehalten - Abbildungen unverbindlich
- RoHS konform, frei von Halogenen (PVC)
- Unsere „Technischen Erläuterungen“ geben Auskunft über den Einsatz von Magneten sowie zu allgemeinen Montage- und Sicherheitshinweisen

- Solenoids manufactured and tested according to DIN VDE 0580
- Forces indicated measured at 20°C ambient and operating temperature with 90% of its rated voltage, in horizontal position
- Force values for reference only and can differ ±10% as a result of natural dispersion
- Special designs are available
- All specifications subject to change without notice
- Compliant with RoHS; free of halogenes (PVC)
- Our „Technical Explanations“ provide information about the use of solenoids as well as to general installation and safety instructions